

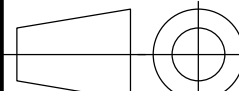
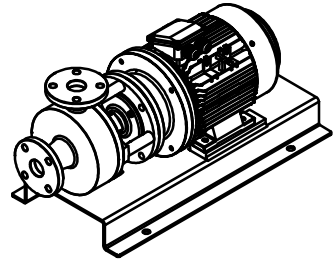
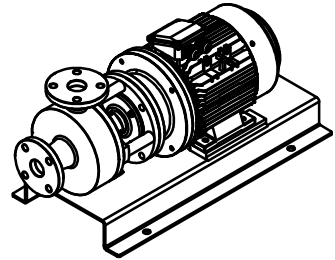
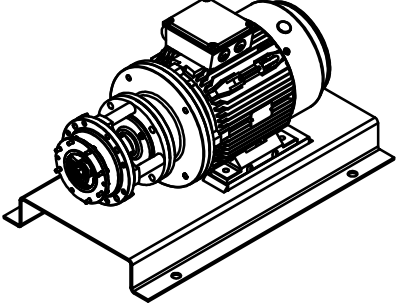
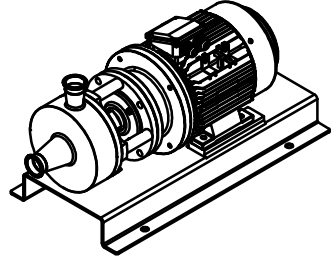
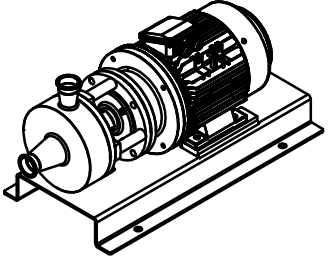
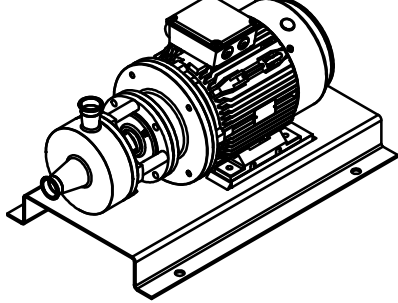
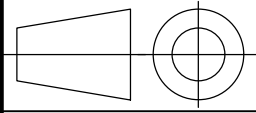

Escala: 1 : 10	Descripción: Emulsionador Ø145 mm monoblock
	 SEVEN PUMPS & MIXERS, S.L.
A3	Código de plano: M.X.O.N.-M 145-(1.3)-RE-BED-( )-((5,5.7,5)-11)

POS.	OPCION	CÓDIGO	DESCRIPCIÓN	CANT.	POS.	OPCION	CÓDIGO	DESCRIPCIÓN	CANT.
1		35BED	Cartucho equilibrado	1	8		DIN 625 SKF - SKF 6213-2Z	Rodamiento rigido de bolas con dos sellos metálicos	1
2	11 kW	2008.145.160	Bancada homogeneizador	1	9		DIN 471 - 65x2,5	Anillo de retención para orificios	1
2	5,5,7,5 Kw	2008.145.132	Bancada homogeneizador	1	10		DIN 3760 - A - 65 x 85 x 10	Retén de labio simple	1
3	11 kW	MS2 160MLA B3B5	Motor 11 kW 3.000 R.P.M.	1	11		JTV120,00X2,62	Tórica 120,00 x 2,62	1
3	7,5 kW	MS2 132SC B3B5	Motor 7,5 kW 3.000 R.P.M.	1	12		2004.145.02	Tapa del rodamiento	1
3	5,5 kW	MS2 132SB B3B5	Motor 5,5 kW 3.000 R.P.M.	1	13		2004.145.03	Separador	1
4	11 kW	DIN 6885 - A 12 x 8 x 90	Chaveta paralela	1	14		2003.145	Caja	1
4	5,5,7,5 kW	DIN 6885 - A 10 x 8 x 70	Chaveta paralela	1	15		JT190,00X3,53	Tórica 190,00 x 3,53	1
5	11 kW	2004.145.160.01	Brida adaptación homogeneizador M.X.O.N.-(-M) 145-(-)RE-(-)(-)11/15/18,5	1	16		M.X.O.N.ROT.DI.145.316	Rotor	1
					17		M.X.O.N.EST.145.316	Estátor	1
5	5,5,7,5 kW	2004.145.132.01	Brida de adaptación	1	18		ARANDELA NORDLOCK M16SP	Arandela Nord-Lock ancha	1
6	11 kW	2005.145.160	Semieje homogeneizador M.X.O.N.-(-M) 145-(-)RE-(-)(-)11/15/18,5	1	19		ISO 8673 - M16	Tuerca hexagonal	1
6	5,5,7,5 kW	2005.145.132	Semieje	1	20	CLAMP	2001.145.3	Cuerpo	1
7		DIN 6885 - A 8 x 7 x 25	Chaveta paralela	1	20	BRIDAS	2001.145.1	Cuerpo homogeneizador M.X.O.N.-M 145-1-RE-(-)(-)(-)	1

MODELOS			
5,5 kW	7,5 kW	11 kW	
			BRIDA
			CLAMP

Escala: 1 : 20	Descripción: Emulsionador Ø145 mm monoblock
	<b>SEVEN</b> SEVEN PUMPS & MIXERS, S.L.
A3	Código de plano: M.X.O.N.-M 145-(1.3)-RE-BED-(-)((5,5,7,5)-11)